

Tailgate Springs

Kg's supported @ 1 Metre

HF001

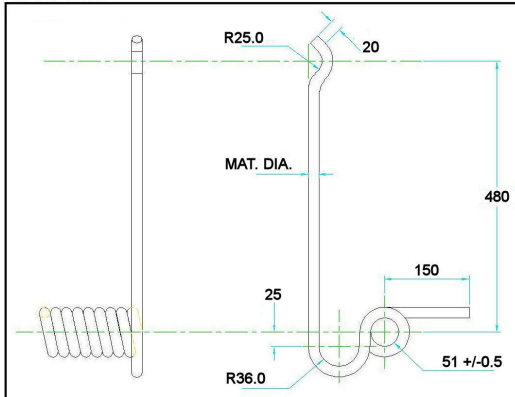

HF002

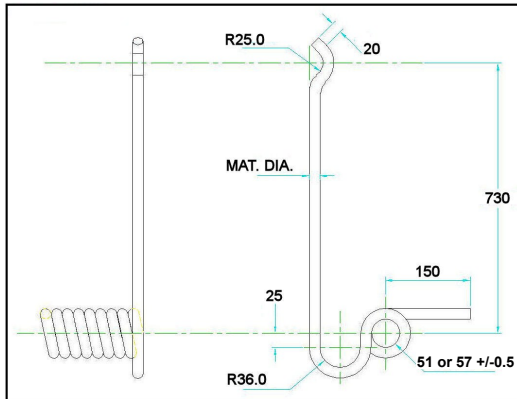

57mm I.D. on 16mm material and up.

HF003

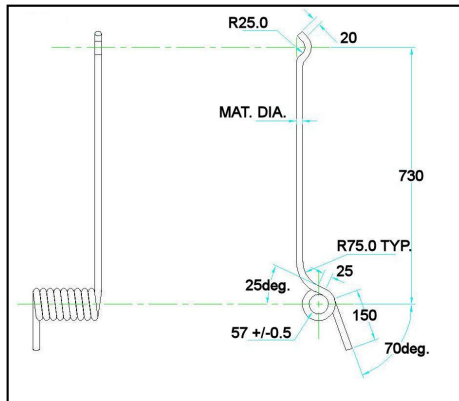

Selecting the correct assist spring

Using the example above right.

EL = 212.5 Kg (when using in pairs divide the load by half, ie. 106.25 Kg)

From the table above HF001/19 would be selected for this application when using a pair.

Note that the tailgate spring is designed to assist with the lifting/lowering and not take the total weight, the ramp or tailgate must overcome the resistance of the spring so that it is able to lay stable on the ground once lowered.

Part No	@ 90°	@ 120°
HF001/13	12	17
HF001/14	17	30
HF001/16	30	50
HF001/17	45	70
HF001/19	90	105
HF002/13	12	17
HF002/14	17	25
HF002/16	30	45
HF002/17	40	55
HF002/19	65	90
HF003/17	40	55
HF003/19	65	90

Material size is the no. after the "/" in the Part no.

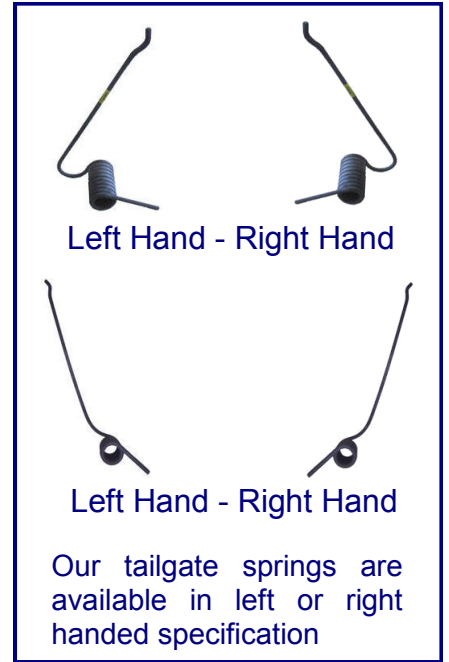

Our tailgate springs are available in left or right handed specification

Load Rating Guide

EL = Estimated Load

W = Weight of tailgate in Kg measured at furthest point

L = Length of tailgate (meters)

EL = W x L

eg. Tailgate length = 2.5m,
Weight at furthest point = 85 Kg

EL = 85 x 2.5

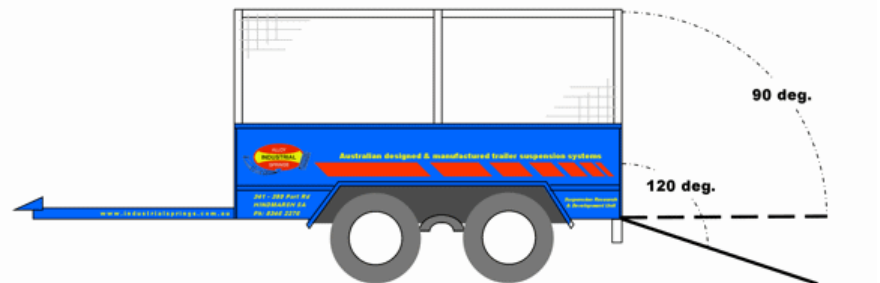

*Avoid any weld spatter on springs as this will result in premature failure.

WHAT WE DO...

SPRINGS

- **Aurora Springs®**
(Automotive springs)
- **Belleville disc springs**
- **Coil springs**
(Agricultural, automotive, industrial, mining & railway)
- **Laminated springs**
(4WD, trailer, truck, repair & reset)
- **Volute springs**
- **Wire springs**
(Clips, compression, tension & torsion)

OTHER PRODUCTS

- **Anchors**
(Grapnel, stockless & admiralty)
- **Anti-roll bars**
- **Chisels, crowbars**
- **Shot peening**
- **Slasher blades**
- **Spring washers**
- **Towing stabiliser kits**
- **Trailer suspension assemblies / fittings**
- **Tynes**
- **Tyre levers**
- **U-bolts**

Our flexible manufacturing systems mean we can manufacture the one off replacement spring or part right up to large production runs. To see what we do in more detail please log on to our web site or alternatively contact one of our friendly staff with your enquiry.



WHO WE ARE...

Australia's largest privately owned spring manufacturer. Since 1935 we have been supplying the Australian and an expanding overseas market with high quality springs and related products.



www.industrialsprings.com.au

Industrial Engineers & Spring Makers
(Sales) Pty. Ltd.

341 - 359 Port Road, HINDMARSH SA 5007

Phone: (08) 8346 2276

Fax: (08) 8340 1721

Email: sales@industrialsprings.com.au